

Application Note
Measuring above 10V with the RT66B
July 22, 2009

Introduction:

The Precision RT66B Ferroelectric Tester will control Radiant's 4kV and 10kV I²C High Voltage Interface units to make measurements at very high voltages. However, unlike the Precision LC and the Precision Premier II, the RT66B does not have an internal amplifier to permit measurements between 10V and 200V without an HVI. Below 200V, a sample breakdown should not generally damage the measurement circuits of the RT66B. Therefore, it is permissible to make measurements with the RT66B *below 200V* without a High Voltage Interface attached to the unit. This application note explains the requirements and procedures for executing such measurements.

Amplifier Specifications:

Any high voltage amplifier may be attached to the DRIVE output of the RT66B to conduct tests above |10V| with two caveats:

- 1) The high voltage amplifier may not exceed 200V
- 2) An I²C ID Module associated with the external high voltage amplifier must be present on the I²C port of the RT66B.

If the ID Module is not present the RT66B will not allow measurements at high voltage to be executed. If the high voltage amplifier exceeds 200V during a test and the sample breaks down, the RT66B may be permanently damaged.

Equipment Configuration

Figure 1 below highlights the signal path for a Precision tester *with an HVI* along with the location of the protection circuitry. There are four paths from the tester:

- 1) DRIVE voltage out
- 2) RETURN current in from the sample
- 3) HV Monitor in from the HVA
- 4) COMM to/from the HVI and HVA ID Module

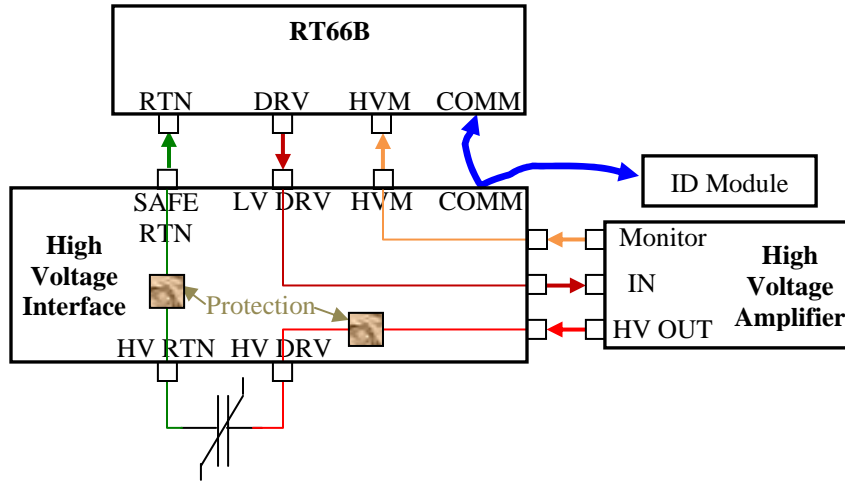

RT66B Connections to HVI, HVA, and Sample
Figure 1

When using a 200V (or less) external amplifier with the RT66B, the HVI need not be used. The connection diagram is in **Figure 2**.

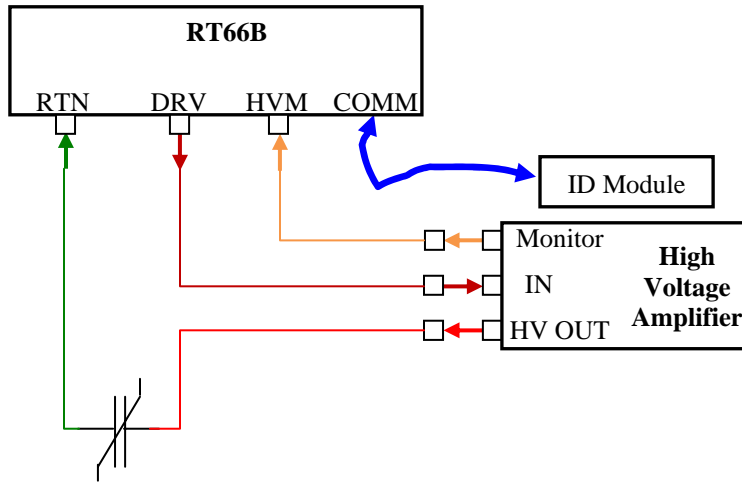

RT66B Connections to HVA, and Sample if not using HVI below 200V
Figure 2

In **Figure 2**, the ID Module must be an I²C version and it must be programmed with the performance parameters of the high voltage amplifier. The appropriate ID Module may be purchased from Radiant.

Low Voltage vs High Voltage in Precision Testers:

The low voltage/high voltage selection in Vision for all testers is executed with the SET AMPLIFIER button on each of the measurement task menus.

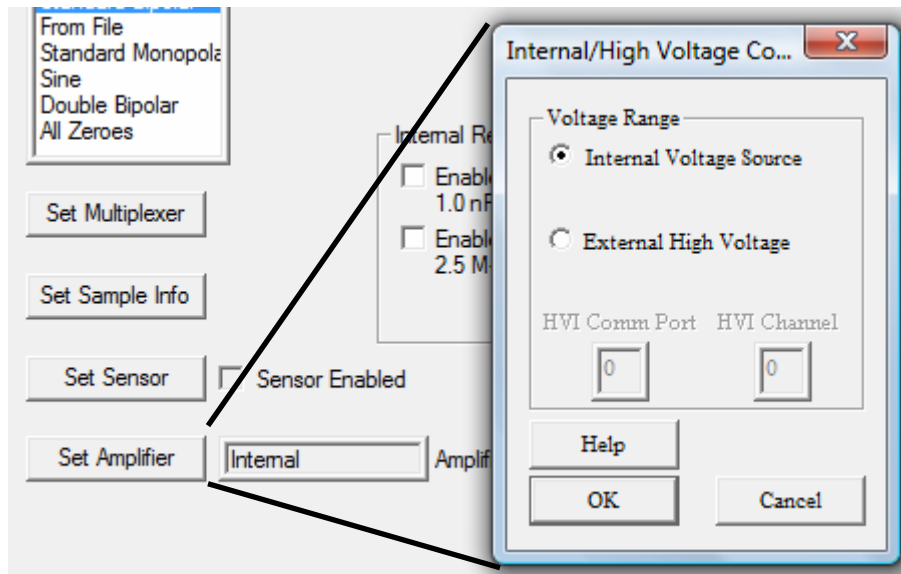

SET AMPLIFIER Menu in Vision
Figure 3

If “Internal Voltage Source” is selected, Vision will direct the assigned voltage (V_{max}) out of the DRIVE BNC. If “External High Voltage” is selected, Vision will divide the assigned voltage (V_{max}) by the amplification factor read from the attached ID Module and output the dividend from the DRIVE BNC. The assumption is that the high voltage amplifier will amplify the reduced DRIVE voltage back to the assigned V_{max} value.

If there is an HVI attached to the tester, Vision will automatically calculate the necessary voltages, configure the HVI, and direct the test waveform to the proper output: the DRIVE BNC when using the “Internal Voltage Source” or the HV DRIVE output of the HVI when “External High Voltage” is selected. You may jump back and forth between low voltage and high voltage mode in software.

Only the RT66B will allow high voltage operation without an HVI but *only at or below 200V*.

IMPORTANT: *If operating without an HVI as in Figure 2 above, the RT66B may only be operated in low voltage mode or in high voltage mode. You may not switch between them in software.*

- 1) If the ID Module is attached to the RT66B with no HVI, the RT66B will only operate in high voltage mode. Any attempt to select “Internal Voltage Source” will result in an error.
- 2) If the ID Module is *not* attached to the RT66B, the RT66B will only operate in low voltage mode even if the HVA is still attached. Any attempt to select “External high Voltage” will result in an error. *Do not leave an HVA attached to the RT66A DRIVE output if the ID Module is not attached to the tester.*

RT66B Operating Procedures

To use the RT66B with an HVA but without an HVI:

- 1) Attach the HVA to the tester and the sample as shown in **Figure 2** above.
- 2) Attach the ID Module associated with the HVA.
- 3) Press the SET AMPLIFIER button and select “External High Voltage”.
- 4) Set all voltages on the test menus in Vision to their actual values. For instance, to execute a 105V hysteresis loop, set Vmax to “105” in the Hysteresis Task.

All other procedures in Vision remain same.

Performance Specifications in High Voltage Mode:

Almost all commercial amplifiers with limits at or below 200V will have frequency responses as fast as or faster than the RT66B. Therefore, the performance specifications for the RT66B configured as in **Figure 2** will most likely remain unchanged.

When executing the DC Bias and Waveform tasks, it is best to ground the RETURN side of the sample so the sample switching is not restricted by the current limit of the RETURN input. The Precision LC and the Precision Premier II both have relays on their RETURN inputs that allow Vision to ground that input during waveform or DC bias activities. The RT66A does not have such a relay. Therefore, to fatigue a sample at high voltage without an HVI, disconnect the sample from the RETURN of the RT66B and connect that side of the sample directly to ground (the green banana plug on the RT66B) as shown in **Figure 4**.

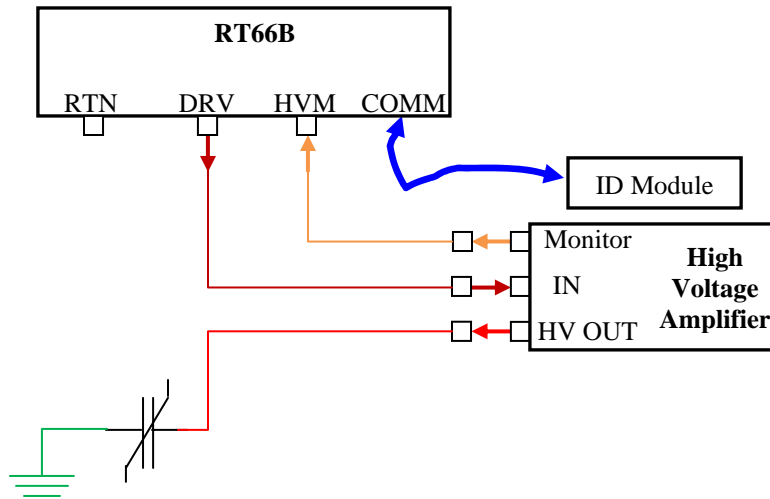

RT66B Connections for DC Bias and Waveform Tasks
Figure 4

When executing a waveform on a sample, it is best to ground one side of the sample instead of leaving it connected to the RT66B RETURN. The Premier II and LC have relays on their RETURN inputs that allow them to ground that side of the sample during waveforms. The RT66B does not have a RETURN GROUND relay and the RETURN input may not have the current capacity to cancel all of the current generated by the sample during high speed cycling. Disconnecting the sample from the RETURN and connecting it to electrical ground ensures that the sample will fully switch when using higher waveform frequencies.

WARNINGS:

- 1) Connect the external HVA to the RT66B and the sample as shown in **Figure 2**.
- 2) To select “External High Voltage” with an RT66B without an HVI, the ID Module for the HVA *must be attached* to the I²C port of the RT66B.
- 3) The RT66B *will not operate in low voltage mode* if an ID Module is attached without an HVI.
- 4) In both high voltage and low voltage operation, *assign the actual voltages* to the Vision menus.
- 5) Never leave a high voltage amplifier attached to the RT66B DRIVE output *without an ID Module attached to the RT66B*.
- 6) Do not use a high voltage amplifier greater than 200V with the RT66B *without an HVI attached*.
- 7) Ground the RETURN side of the sample *when executing high speed waveforms*.