

9 April, 2009

From: Scott P. Chapman
Radiant Technologies, Inc.
To: Precision LC and Premier II Tester Owners

Subj: LC and Premier II Tester Description and Configuration

Dear Precision LC and Premier II Owner,

Note: This document now pertains to both the Precision LC and Precision Premier II Test Systems. The discussion will refer to the test system with the generic term, "Tester".

This letter accompanies the delivery of your Precision Test System. It is a companion document to the Vision software installation instructions. This letter describes the physical appearance of the tester, detailing controls and connections on both the front and rear panels. It also details connections to be made between the Precision tester and attached accessories including the High Voltage Interface (HVI)/High Voltage Amplifier (HVA) pair and the 48-Channel Multiplexer.

Standard Configuration

Figure 1 shows the LC front panel. (The Premier II differs only in labeling.) It is a very simple display with a single control ("POWER"), two signal BNCs ("DRIVE" and "RETURN") and a red and a green LED. The Power switch simply turns the tester on or off. Note that the tester must be turned on before the Vision software is run, or the unit will not be detected.

NOTE: If you start Vision before turning on the Tester and you are running V3.2 Vision, you must stop Vision, turn on the Tester, and re-start Vision.

NOTE: If you start Vision before turning on the Tester and you are running V4.1 Vision, you may connect to the Tester after it is turned on by pressing ALT-W. Vision will find and load the tester and present a control stating what testers are connected. If it still does not see the tester, press ALT-W one more time.

When power is applied to the unit, the red LED is illuminated.

The Drive BNC is normally connected to one electrode of the sample under test. The Drive ports on the front and rear panels are electrically identical. The Return port is connected to the opposite sample electrode. Front and rear panel Return connectors are also electrically identical. To make high voltage measurements through a High Voltage Interface, the sample is connected to the HVI, not the tester. (See the explanation below.)

The Green LED is normally off when the tester is first turned on. When the tester is loaded by Vision, the Green LED will begin to blink once every two seconds. If it does not illuminate or if it turns on solid, Vision will not be able to communicate with the tester. In that case, turn the tester off and then on and re-load it into Vision. The Green LED extinguishes when the Vision software is ordering the tester to apply a drive voltage to the sample. During the execution of a Measurement Task in Vision, this LED may extinguish and re-illuminate several times as the software adjusts the measurement parameters. Measurements may take several minutes. When the LED returns to a continuously blinking state, the measurement is completed.

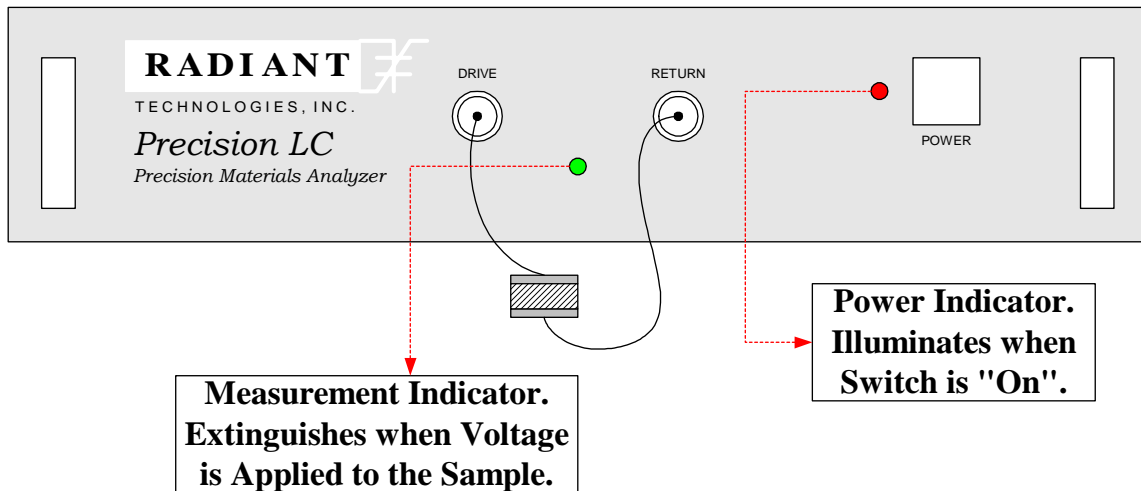

Figure 1 – Precision LC Front Panel.

Figure 2 shows the Precision tester rear panel. This is a more complex organization of connections and controls than the front panel. However, basic configuration is very simple. The rear panel consists of a single green banana connector that provides case ground to the system, a single USB connector, a DB-25 connector, an AC power connector, a set voltage indicator and seven BNC connectors. The use of these features is detailed in **Table 1**.

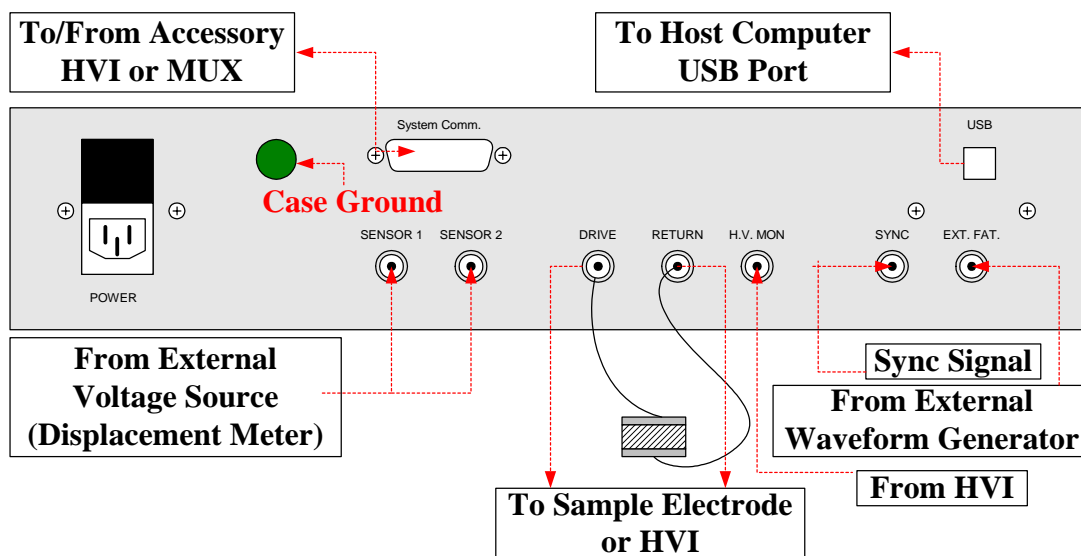

Figure 2 – Precision Tester Rear Panel.

Table 1 – Precision Tester Rear Panel Connections.

Label	Description
Power	The Precision tester power supply is self-switching between 120V and 220V. Damage to the tester from improperly switched power is not a concern.
None	A green banana connector tied directly to the Precision tester case forming a case ground. If Precision accessories such as a High Voltage Interface (HVI) and High Voltage Amplifier (HVA) or a 48-Channel Multiplexer are connected to the tester, these must have their grounding connectors connected together. It is also a very good policy to connect experimental apparatus such as probe stations, optical benches, etc. to this common point.
System Comm.	A DB-25 connector that is used to attach the Precision tester to Precision accessories so that digital logic data can be transmitted between the tester and the accessories. This communication allows the Vision software to detect the presence and type of accessory. Vision will not allow software to try to communicate to an accessory if this communication is not established. Accessories include a High Voltage Interface (HVI)/High Voltage Amplifier (HVA) pair or a 48-Channel Multiplexer.
USB	A standard USB cable is used to connect the Precision tester, at this connector, to the host computer onto which Vision has been loaded. The host must have a USB port and must be running Windows 2000, Windows XP, or Windows Vista. (Windows NT may also be used provided the user installs a third-party NT USB driver. USB is not normally supported by NT. Such drivers are available, but have not been evaluated by Radiant Technologies, Inc. Operation under Windows Vista has been verified, provided the program is set to run in XP mode.) Once connected, after loading Vision, the host operating system will detect new hardware when the tester is first powered up. The specific driver for the tester must then be loaded. Refer to the Software Installation letter for detailed instructions on loading that driver.
SENSOR 1	When making any measurement, the Vision software is capable of simultaneously capturing one or two external voltage signals, provided the signal is in the range ± 10.0 Volts. The Vision software then applies a transform in the form

	<p style="text-align: center;">$\text{Response} = m \times \text{Sensed Voltage} + b$</p> <p>To turn the detected signal into a meaningful physical value. This feature is most commonly used to capture sensor displacement using a displacement meter that provides a voltage signal that is linearly related to displacement when doing a piezoelectric measurement. Other potential uses might include the capturing of temperature or optical intensity. One of the external voltage signals may be connected at this port.</p>
SENSOR 2	<p>When making any measurement, the Vision software is capable of simultaneously capturing one or two external voltage signals, provided the signal is in the range ± 10.0 Volts. The Vision software then applies a transform in the form</p> <p style="text-align: center;">$\text{Response} = m \times \text{Sensed Voltage} + b$</p> <p>To turn the detected signal into a meaningful physical value. This feature is most commonly used to capture sensor displacement using a displacement meter that provides a voltage signal that is linearly related to displacement when doing a piezoelectric measurement. Other potential uses might include the capturing of temperature or optical intensity. A second external voltage signal may be connected at this port.</p> <p>NOTE: The Vision software is not yet equipped to detect this second Sensor channel.</p>
DRIVE	<p>The Vision software causes the Precision tester to apply a voltage signal either directly to the sample or to the SYSTEM DRIVE port of the HVI (in a high voltage measurement) through this BNC connector. When applying a voltage directly to a sample electrode, the sample is normally connected to the DRIVE BNC on the tester front panel. That port is electrically identical to this DRIVE port. For high voltage, this port will normally be connected to the HVI. This port is also used to connect the drive signal to a 48-Channel Multiplexer if present.</p>
RETURN	<p>Current induced in a sample by the application of a drive voltage is returned to the Precision tester through this port. The signal either arrives directly from the sample electrode or is passed to the tester from a High Voltage Interface (HVI) in a high voltage measurement. In that case, this port is connected to the HVI SYSTEM RETURN BNC. Note that when the signal is attached directly to the sample electrode, the RETURN BNC on the tester front panel is normally used. That connection is electrically identical to the rear connection. As a consequence, the rear port will normally be used when connected to an HVI. The port may also be connected to the sample through a 48-Channel Multiplexer.</p>
H.V. MON	<p>This port is only used during a high voltage measurement. It is connected to the HVI at the HVI SYSTEM HV MON BNC. The High Voltage Amplifier (HVA) reports to the tester the actual voltage applied to the sample (and then to the Vision software) through this port. In this way, the exact drive voltage applied, rather than the software-intended drive voltage, can be captured, recorded and plotted.</p>
SYNC	<p>During every measurement operation, the Tester will perform several self-calibrations before it stimulates the sample and records the response. The SYNC port outputs 5V during and only during the stimulus portion of the measurement operation. When SYNC is high, the tester is stimulating the sample and measuring the results. SYNC can be used to trigger an oscilloscope or other instrument when the measurement is being made.</p>
EXT. FAT.	<p>The Fatigue Task provides a variety of options for applying a fatiguing voltage waveform to the sample. Among these options is the ability to switch an externally generated waveform through the Precision tester hardware directly to the sample. Such an external waveform would be connected to this port and switched to the sample electrode when selected in software.</p>

High Voltage Hook Up

NOTE: The user should read through the TREK amplifier documentation. However, the accessory hookup should proceed as described here, not as described in the TREK documents.

NOTE: The sample is tested in High Voltage by connecting it to the front panel of the HVI as shown in Figure 4. It is not tested in High Voltage by connecting it to the DRIVE and/or RETURN ports of the Precision tester. Low Voltage testing is done with the sample connected directly to the tester's DRIVE and RETURN ports.

NOTE: If the High Voltage Amplifier (HVA) is purchased through Radiant Technologies, Inc., the ID Module will be attached to the HVA rear panel. If the amplifier is purchased separately, the ID Module will be delivered as an independent accessory. A sticky back is provided with the independent ID Module to allow it to be attached to the HVA by the customer.

In a high voltage measurement signals created by the Precision tester are directed to a sample through a High Voltage Amplifier (HVA). The HVA serves to raise the low voltages created by the tester to the high voltage required to drive the sample by applying a constant gain factor to the input signal. Signals pass to the amplifier and from the sample through a High Voltage Interface (HVI). The HVI serves a number of functions. The primary function is a high voltage signal buffer that will protect the tester and a human operator if the sample breaks down and high voltage is applied to the HVI return port. Several methods of protection are used including high-speed relays that open immediately on detecting the high voltage signal.

The HVI also acts as a switch. Two separate HVAs may be attached to a single HVI (available in the 10 kV HVI, not the 4 kV HVI), allowing different gain factors and different maximum voltages to be available in a single test configuration. The HVAs are switched in the HVI by making appropriate selections in the Vision software.

Such switching leads to the third and final purpose of the HVI. It serves as a vehicle for the transmission of digital logic data between both the HVI and the HVA and the tester and, ultimately, the Vision software. Such signaling allows the HVI to indicate its presence and the presence of an HVA on the software-selected channel. It allows channels to be switched and indicates the type of HVA present on a channel. Vision will not make a high voltage measurement unless logical agreement is reached that the HVI is present and that the appropriate amplifier is also present on the selected channel.

In configuring the tester/HVI/HVA, it is normal practice to stack the units as in **Figure 3**.

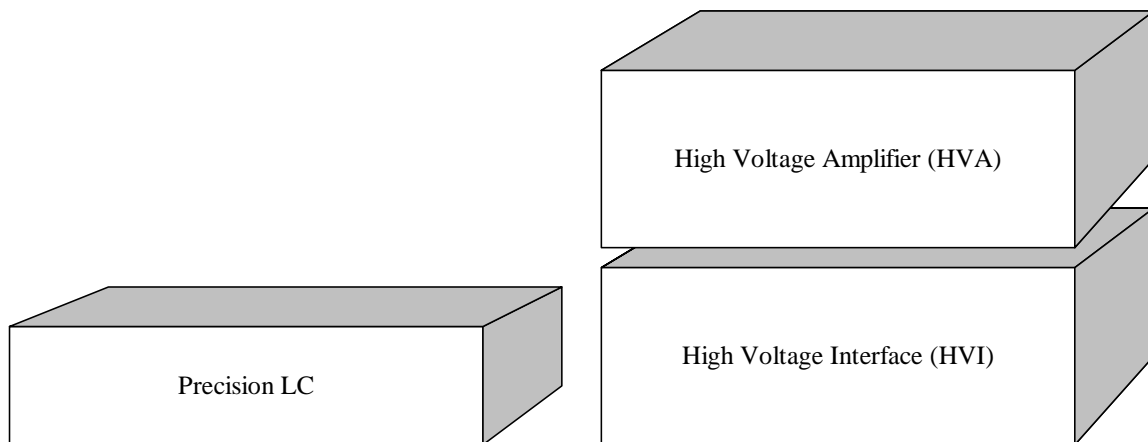

Figure 3 – High Voltage Component Stacking.

Figure 4 shows the HVI front panel. The panel is very simple, consisting only of a power switch, two high voltage connectors and two LEDs. POWER is a simple on/off switch that applies or removes power to the High Voltage Interface.

WARNING: Unlike the Precision Tester, the HVI unit must be set for the power to be used: 110V or 220V. The selection window is on the rear panel of the HVI. Do not apply power to the HVI until you have verified that the voltage applied agrees with the voltage setting on the HVI rear panel. Do not apply power until the Precision tester, the HVI and the HVA are all fully cabled and configured as described in this document. It is especially critical that all components be well grounded together using the Green Banana Plugs on the rear of each unit.

When power is applied, the red LED adjacent to the power switch will illuminate.

The DRIVE and RETURN ports are each connected to the top and bottom sample electrodes to provide the stimulus (DRIVE) and capture the sample response to that stimulus (RETURN). Connections are made using the high voltage cabling provided with the HVI (**Figure 5**).

The drive signal is first created for a Measurement Task in Vision software. The signal is built so that the Precision tester will drive the HVI/HVA amplifier pair with a voltage that is the intended voltage divided by the amplifier gain. That stimulus voltage is passed through the HVI to the HVA. The HVA applies a gain and passes the high voltage signal back to the HVI, which, in turn, passes it through to the sample. (The amplifier also creates a low-voltage representation of the high voltage signal and passes it back to the tester, through the HVI via the MONITOR ports. This allows the software to plot the actual applied voltage rather than relying on the intended voltage.) When a high voltage signal is present at the DRIVE port, the HIGH VOLTAGE ENABLED LED will illuminate indicating that dangerous voltages are present.

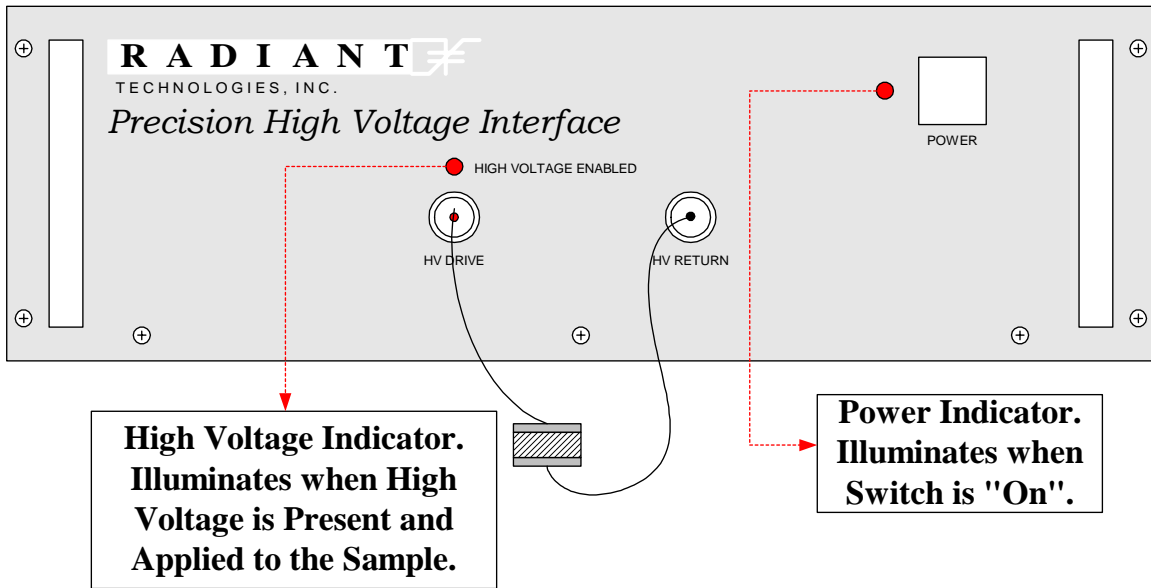

Figure 4 – High Voltage Interface (HVI) Front Panel.

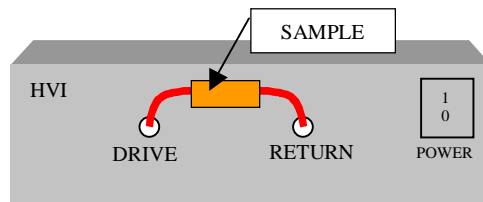

Figure 5 – Sample Connection to the HVI.

The HVI rear panel is shown in **Figure 6**.

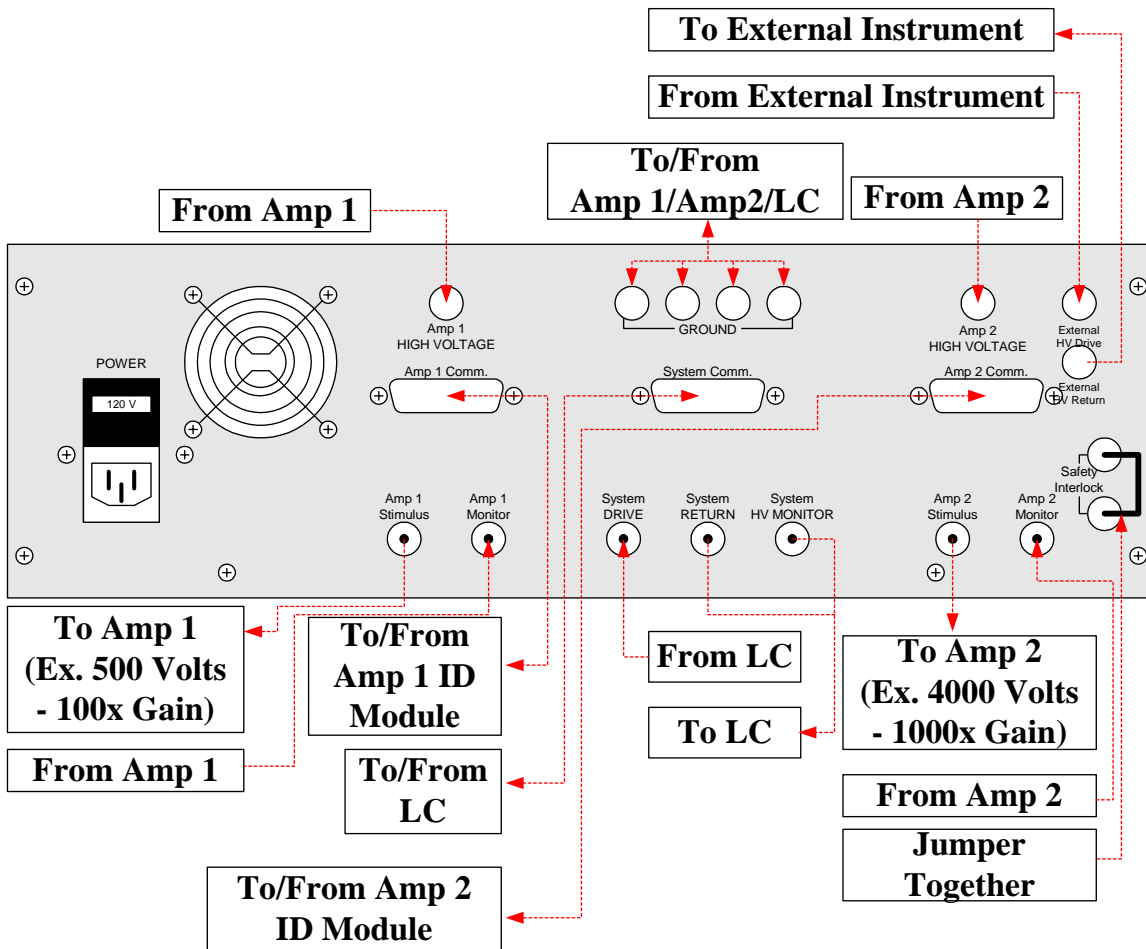

Figure 6 – High Voltage Interface (HVI) Rear Panel.

NOTE: Figure 6 shows the 10 kV edition of the High Voltage Interface. The 4 kV edition has the Amp 1 connectors with the same labels, but only connects to a single amplifier. Amp 2 connectors are absent. The External HV Drive and External HV Return connectors are also absent on the 4 kV HVI.

The rear panel of the HVI consists of a standard AC power connection, four high voltage connectors, four green grounding banana connectors, three DB-25 digital logic connectors, seven BNCs and two additional banana connectors that are shipped jumpered together to provide a safety interlock. These connections provide full interconnection between two High Voltage Amplifiers (HVAs) and the Precision tester. Each connector is discussed in detail in **Table 2**. Note that the various “Amp 2” ports presented in the table are available only on the 10 kV HVI. The 4 kV HVI only has a single amplifier channel.

Table 2 – High Voltage Interface (HVI) Rear Panel Connections.

Label	Discussion
Power	The Precision HVI power supply is self-switching between 120V and 220V. Damage to the tester from improperly switched power is no longer a concern. NOTE: if you have an HVI purchased before 2007, it may have a manual selection window for the supply voltage. Be sure to check this selection before applying power to the unit.
Amp 1 HIGH VOLTAGE	A high voltage connector carrying the high voltage drive signal from High Voltage Amplifier 1. It is connected directly to the high voltage output (HV OUT) on the front or rear panel of the amplifier. The signal is passed through the HVI to the HV DRIVE port on the front panel and from there to the sample. Selection between the Amp 1 and Amp 2 drive signal is made in Vision software and switched through logic connections between the Precision tester and the HVI.
GROUND	Four green banana connectors tied directly to the HVI case forming a case ground. The Precision tester, the HVI and the HVA must have their grounding connectors connected together. It is also a very good policy to connect experimental apparatus such as probe stations, optical benches, etc. to this common point.
Amp 2 HIGH VOLTAGE	A high voltage connector carrying the high voltage drive signal from Amplifier 2. It is connected directly to the high voltage output (HV OUT) on the front or rear panel of the high voltage amplifier #2. The signal is passed through the HVI to the HV DRIVE port on the front panel and from there to the sample. . Selection between the Amp 1 and Amp 2 drive signal is made in Vision software and switched through logic connections between the Precision tester and the HVI.
External HV Drive	A high voltage signal can be passed from an external signal generator, through the HVI and directly to the sample connected to the HVI front panel HV DRIVE port. Making this connection is initiated in Vision software and switched through logic connections between the Precision tester and the HVI. Execute the HVI AUX task to utilize this port. Only the 10kV HVI has this capability.
External HV Return	The sample response to a drive signal can be passed through the HV RETURN port at the HVI front panel and out this port on the rear panel directly to an external instrument. In this case the tester does not capture the signal. Making this connection is initiated in Vision software and switched through logic connections between the Precision tester and the HVI. Execute the HVI AUX task to utilize this port. Only the 10kV HVI has this capability.
Amp 1 Comm.	This is a DB-25 connector that transmits digital logic to and from the Amplifier 1 ID Module. It is connected to the ID Module shipped with the HVI. NOTE: In HVI/Amplifier sets shipped since 2005, this connector on the amplifier has been replaced by the separate ID Module.
System Comm.	This is DB-25 connector that establishes digital logic communication between the HVI and the Precision tester. It is connect to the System Comm. DB-25 connector on the rear panel of the tester.
Amp 2 Comm.	This is a DB-25 connector that transmits digital logic to and from Amplifier 2 ID Module. It is connected to the ID Module shipped with the HVI. NOTE: In HVI/Amplifier sets shipped since 2005, this connector on the amplifier has been replaced by the separate ID Module.
Amp 1 Stimulus	This BNC connector provides a low voltage drive stimulus signal from the tester to Amplifier 1. It is connected to the Stimulus port on the front or rear panel of the amplifier. This stimulus voltage is multiplied by the amplifier gain factor to produce the high voltage output signal that is passed back to the HVI from the Amp 1 HIGH VOLTAGE port. Amplifier 1 Stimulus is selected in the Vision software and switched by digital logic signal from the Precision tester to the HVI.
Amp 1 Monitor	This is a low voltage signal from High Voltage Amplifier 1 to the HVI that indicates the actual voltage being output by the amplifier divided by the amplifier gain factor.

	This port is connected to the Monitor port on the rear panel of the amplifier. The reported voltage should be identical, or nearly identical, to the Amp 1 Stimulus voltage. This voltage allows Vision to more accurately represent the stimulus on the sample. The signal is passed to the Precision tester through the System HV MONITOR port. Amplifier 1 Monitor is selected in the Vision software and switched by digital logic signal from the Precision tester to the HVI.
System DRIVE	This BNC receives a low voltage stimulus waveform from the Precision tester. It is connected to the DRIVE BNC on the tester front or rear (normally rear) panel. The signal is routed to Amplifier 1 or Amplifier 2 through Amp 1 Stimulus or Amp 2 Stimulus ports. The target amplifier is selected in Vision software and switched by digital logic signal from the tester to the HVI.
System RETURN	This BNC connector passes the sample response current from the HV RETURN port on the HVI front panel to the Precision tester. The port is connected to the RETURN BNC on the tester front or rear (normally rear) panel. The tester captures and integrates this signal and returns the data to the Vision software for display, storage and analysis.
System HV MONITOR	This BNC returns a low voltage signal from the amplifier to the Precision tester. It is connected to the H.V. MON BNC on the tester rear panel. The signal is linearly related to the high voltage signal present on the selected high voltage amplifier output by dividing that signal by the amplifier gain. This value should be nearly identical to the low voltage stimulus signal provided by the tester. However, it provides a more accurate representation of the actual signal being applied to the sample. This signal is passed through the HVI from either the Amp 1 Monitor or Amp 2 Monitor port. The port is selected in Vision software and switched by digital logic signal from the tester to the HVI.
Amp 2 Stimulus	This BNC connector provides a low voltage drive stimulus signal from the tester to Amplifier 2. It is connected to the Stimulus port on the rear panel of the amplifier. This stimulus voltage is multiplied by the high voltage amplifier gain factor to produce the high voltage output signal that is passed back to the HVI at the Amp 2 HIGH VOLTAGE port. Amplifier 2 Stimulus is selected in the Vision software and switched by digital logic signal from the Precision tester to the HVI.
Amp 2 Monitor	This is a low voltage signal from Amplifier 2 to the HVI that indicates the actual voltage being output by the amplifier divided by the amplifier gain factor. This port is connected to the Monitor port on the rear panel of the amplifier. The reported voltage should be identical, or nearly identical, to the Amp 2 Stimulus voltage. This voltage allows Vision to more accurately represent the stimulus on the sample. The signal is passed to the Precision tester through the System HV MONITOR port. Amplifier 2 Monitor is selected in the Vision software and switched by digital logic signal from the Precision tester to the HVI.
Safety Interlock	These two banana connectors must be jumpered together to allow the HVI to operate or high voltages to be generated. A jumper is shipped in place with the HVI so that it is immediately ready to operate. If the two banana connectors are not shorted during a test, the HVI cannot connect high voltage the HV DRIVE output on the front panel of the HVI. The Safety Interlock can be used by the researcher to prevent high voltage generation unless specific safety conditions are met.

Amplifier appearance and connections vary slightly depending on the amplifier in question. 500-Volt, 2,000-Volt and 4,000-Volt amplifiers are functionally identical. Because of safety issues, the 10,000-Volt amplifier has different connector types and additional controls on the front panel. **Figures 7 and 8** show a 2,000-Volt Amplifier front and rear panels. **Figures 9 and 10** refer to the 10,000-Volt Amplifier. **NOTE: Figures 7 through 10 are representative examples of amplifiers. There are many different amplifiers that may be used with the Precision tester series. Some may have different labels on their controls and some may have some or all controls on the front panel.**

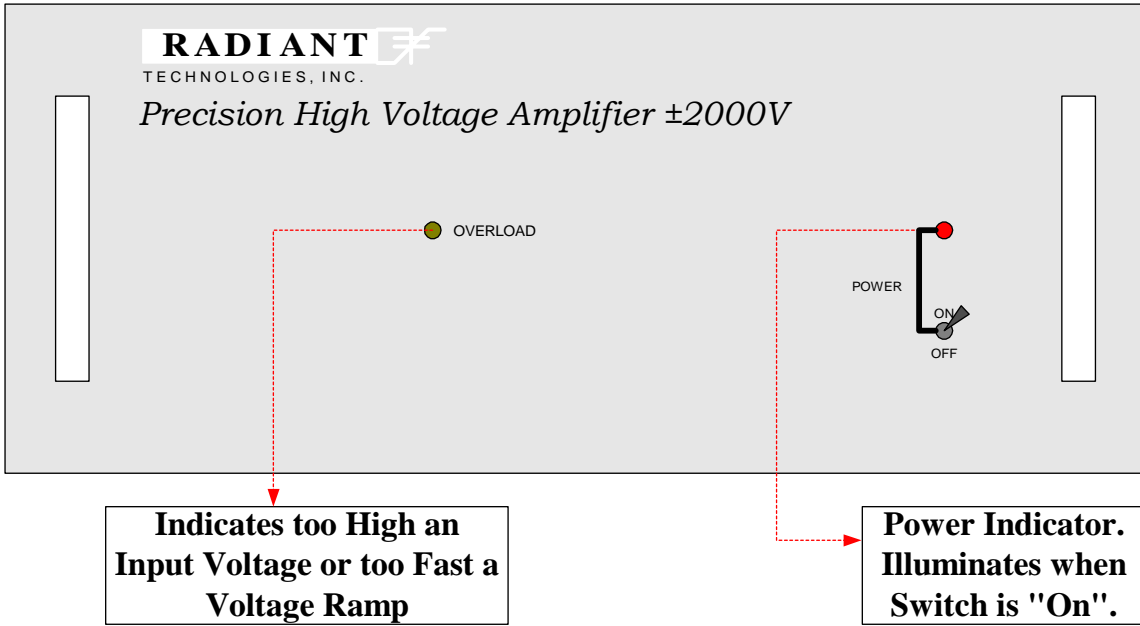

Figure 7 – ±2,000-Volt High Voltage Amplifier (HVA) Front Panel.

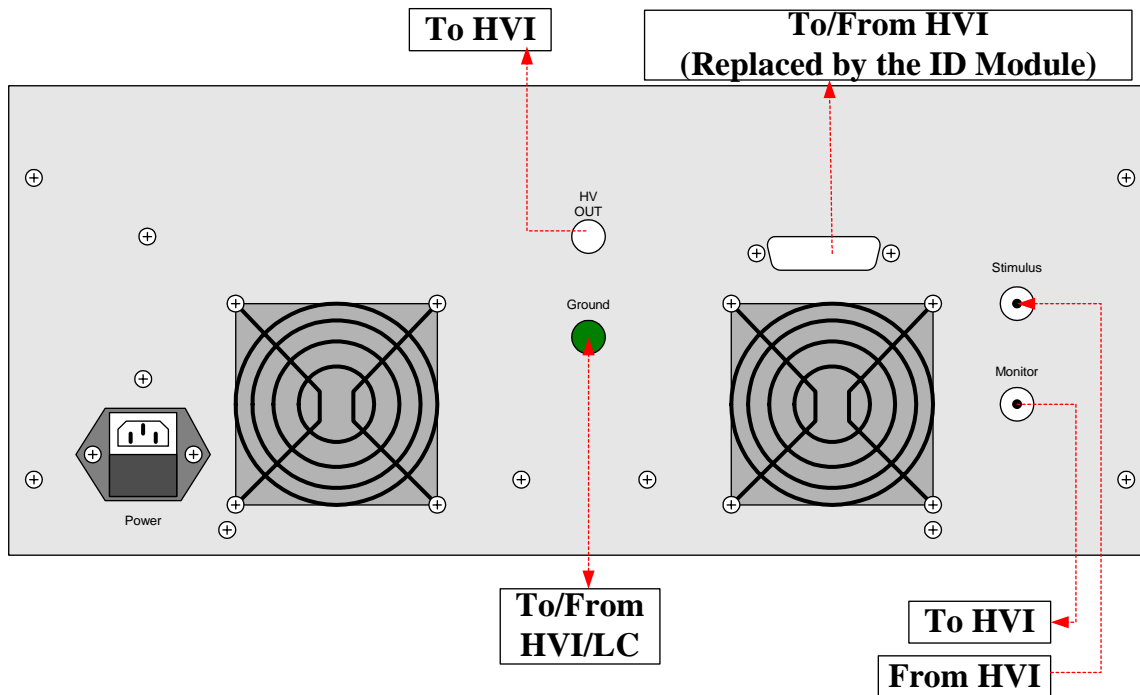

Figure 8 – ±2,000-Volt High Voltage Amplifier (HVA) Rear Panel.

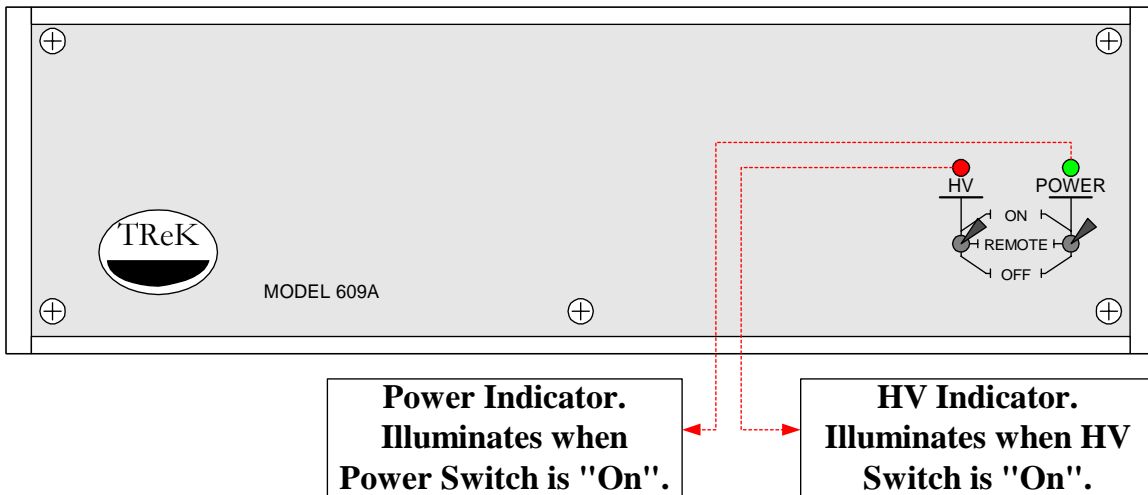

Figure 9 – ±10,000-Volt High Voltage Amplifier (HVA) Front Panel.

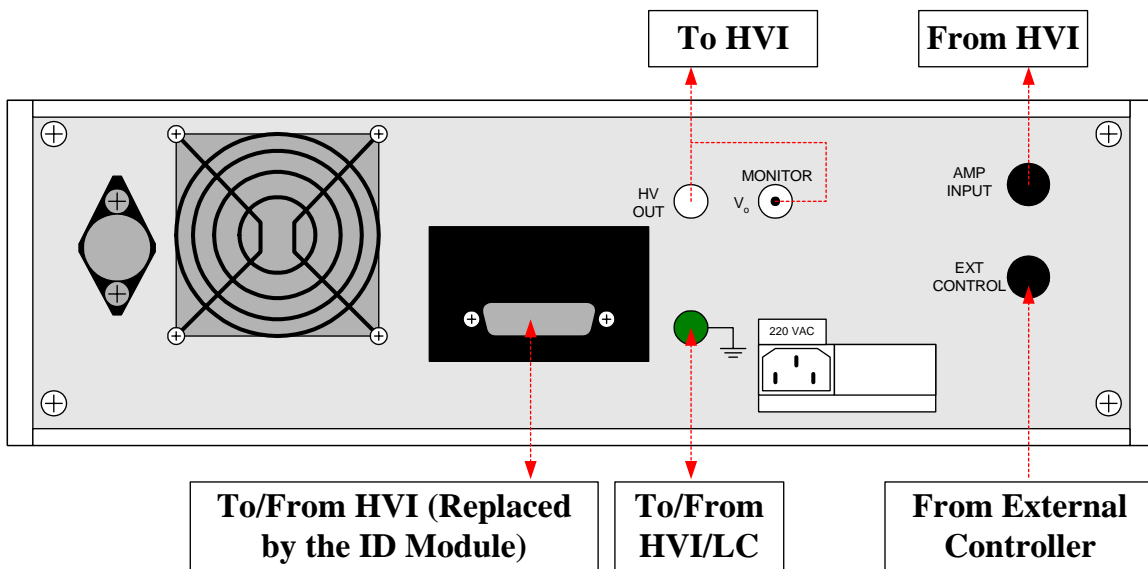

Figure 10 – ±10,000-Volt High Voltage Amplifier (HVA) Rear Panel.

**Table 3 – 2,000-Volt and 10,000 Volt High Voltage Amplifiers
Front and Rear Panel Connections and Indicators.**

Label	Discussion
2,000-Volt Front Panel	
Overload	Amber LED. This LED illuminates when the input stimulus voltage exceeds the rating of the amplifier or when the rate of increase of the input stimulus voltage exceeds the amplifier rating. This is an error condition. Slow down the speed of the test until the overload indication goes away.
Power	Red LED. Illuminates when the amplifier is on an high voltage is available. Do not apply power to the amplifier until all connections are made as described in this document. Do not apply power to the amplifier until you have verified that the input line voltage matches the labeled voltage on the amplifier rear panel.
Power	Toggle switch. Turns the amplifier off and on. Do not apply power to the amplifier until all connections are made as described in this document. Do not apply power to the amplifier until you have verified that the input line voltage matches the labeled voltage on the amplifier rear panel.
2,000-Volt Rear Panel	
Power	Standard AC power connection. Ensure that the line power matches the 120V or 220V label on the Amplifier rear panel.
HV OUT	High Voltage connector attached to the HVI rear panel Amp 1 HIGH VOLTAGE or Amp 2 HIGH VOLTAGE connector. This is the high voltage output of the amplifier. It is linearly related to the low voltage stimulus by the amplifier gain factor. This signal is passed through the High Voltage Interface (HVI) to the sample.
Ground	Green banana connector. This connector is attached directly to the HVA chassis forming a case ground. This connector must be attached to the ground connectors on the HVI and the Precision tester before power is applied to the amplifier. It is a good practice to connect apparatus in the experimental configuration, such as probe stations, optical tables and/or metal benches, to this ground point.
Unlabeled	DB-25 connector. Digital logic to and from the HVI, connected to the Amp 1 Comm. Or Amp 2 Comm. DB-25 connector on the HVI rear panel. This connection provides amplifier identifying information to the Precision tester so that the proper amplifier may be selected in the Vision software. NOTE: In HVI/Amplifier sets shipped since 2005, this connector on the amplifier has been replaced by the separate ID Module.
Stimulus	BNC. A low-voltage amplifier stimulus that is scaled by the amplifier gain factor to create the high voltage amplifier output drive profile. This connector is attached to the Amp 1 Stimulus or Amp 2 Stimulus ports on the rear panel of the HVI. This signal is received by the amplifier from the tester through the HVI.
Monitor	BNC. A low-voltage representation of the actual high voltage signal being output by the amplifier. This signal is passed to the tester through the HVI so that the Vision software can record the actual applied voltage instead of the intended voltage. This signal is connected to the Amp 1 Monitor or Amp 2 Monitor BNC on the HVI rear panel.
10,000-Volt Front Panel	
HV	Red LED. Indicates that high voltage is enabled and may be present at the amplifier output. Do not enable high voltage until all connections are made as described in

	this document. Do not apply power to the amplifier until you have verified that the input line voltage matches the labeled voltage on the amplifier rear panel.
HV	Toggle switch. Sets high voltage output to “ON” (enabled – High voltage may be present at the amplifier output) “OFF” (disabled – high voltage is not present at the amplifier output) or “REMOTE”. In the latter case, the further enabling of high voltage output is controlled by an external instrument. Do not enable high voltage until all connections are made as described in this document. Do not apply power to the amplifier until you have verified that the input line voltage matches the labeled voltage on the amplifier rear panel.
POWER	Green LED. Indicates that line power is available to the amplifier. Does not, by itself, indicate that high voltage may be present at the amplifier output. Do not apply power to the amplifier until all connections are made as described in this document. Do not apply power to the amplifier until you have verified that the input line voltage matches the labeled voltage on the amplifier rear panel.
POWER	Toggle switch. Sets amplifier line power to “ON” (enabled – line power is present in the amplifier) “OFF” (disabled – line power is not present within the amplifier) or “REMOTE”. In the latter case, the supply of line power to the amplifier is controlled by an external instrument. Do not apply power to the amplifier until all connections are made as described in this document. Do not apply power to the amplifier until you have verified that the input line voltage matches the labeled voltage on the amplifier rear panel.
10,000-Volt Rear Panel	
Unlabeled	DB-25 connector. Digital logic to and from the HVI, connected to the Amp 1 Comm. Or Amp 2 Comm. DB-25 connector on the HVI rear panel. This connection provides amplifier identifying information to the Precision tester so that the proper amplifier may be selected in the Vision software. NOTE: In HVI/Amplifier sets shipped since 2005, this connector on the amplifier has been replaced by the separate ID Module.
HV OUT	High Voltage connector attached to the HVI rear panel Amp 1 HIGH VOLTAGE or Amp 2 HIGH VOLTAGE connector. This is the high voltage output of the amplifier. It is linearly related to the low voltage stimulus by the amplifier gain factor. This signal is passed through the High Voltage Interface (HVI) to the sample.
MONITOR	BNC. A low-voltage representation of the actual high voltage signal being output by the amplifier. This signal is passed to the tester through the HVI so that the Vision software can record the actual applied voltage instead of the intended voltage. This signal is connected to the Amp 1 Monitor or Amp 2 Monitor BNC on the HVI rear panel.
Unlabeled (Earth Ground Symbol)	Green banana connector. This connector is attached directly to the HVA chassis forming a case ground. This connector must be attached to the ground connectors on the HVI and the Precision tester before power is applied to the amplifier. It is a good practice to connect apparatus in the experimental configuration, such as probe stations, optical tables and/or metal benches, to this ground point.
120 VAC or 220 VAC	Standard AC power connection. Ensure that the line power matches the 120V or 220V label on the Amplifier rear panel.
AMP INPUT	Three-pin make TREK connector. A low-voltage amplifier stimulus that is scaled by the amplifier gain factor to create the high voltage amplifier output drive profile. This connector is attached to the Amp 1 Stimulus or Amp 2 Stimulus ports on the rear panel of the HVI. This signal is received by the amplifier from the tester through the HVI.
EXT CONTROL	Eight-pin female TREK connector. This connector allows an external instrument to be attached to the amplifier to control line power and high voltage enabling. See the amplifier manual for more details. This connector is not used by Radiant Technologies, Inc.

Connections

The following figures and tables describe the connection of the tester, the HVI and the HVA. **Figure 11** shows the connections required to use a 2,000-Volt amplifier on HVI amplifier channel 1. The Vision software must specify that the amplifier is 2,000 Volts and that it is to be switched through HVI channel 1.

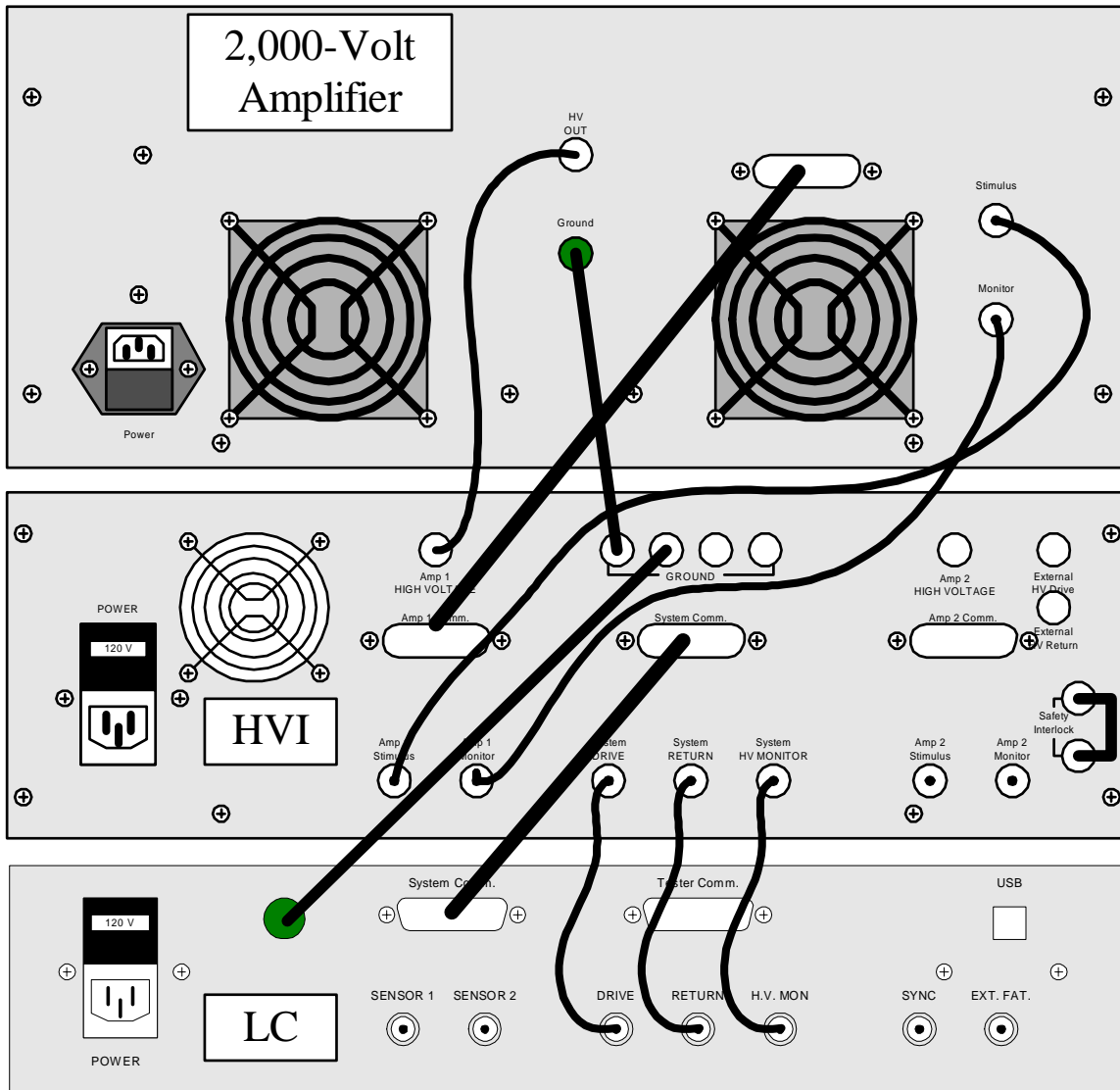

Figure 11 – Required Connections to Make a 2,000-Volt Amplifier Available on HVI Channel 1.

Precision 10 kV HVI II

As of April, 2009, Radiant Technologies, Inc. offers the Precision 10 kV HVI II. This High-Voltage Interface is identical to the 10 kV HVI of **Figures 4** and **6** except that:

- Its height has been reduced to 1u.
- The three D-Type printer cable data connectors have been replaced by three I2C-Type connectors that are accommodated by I2C ports on the Precision Premier II and Precision LC II testers.

The front and rear panels of the new HVI are shown in **Figures 12** and **13**.

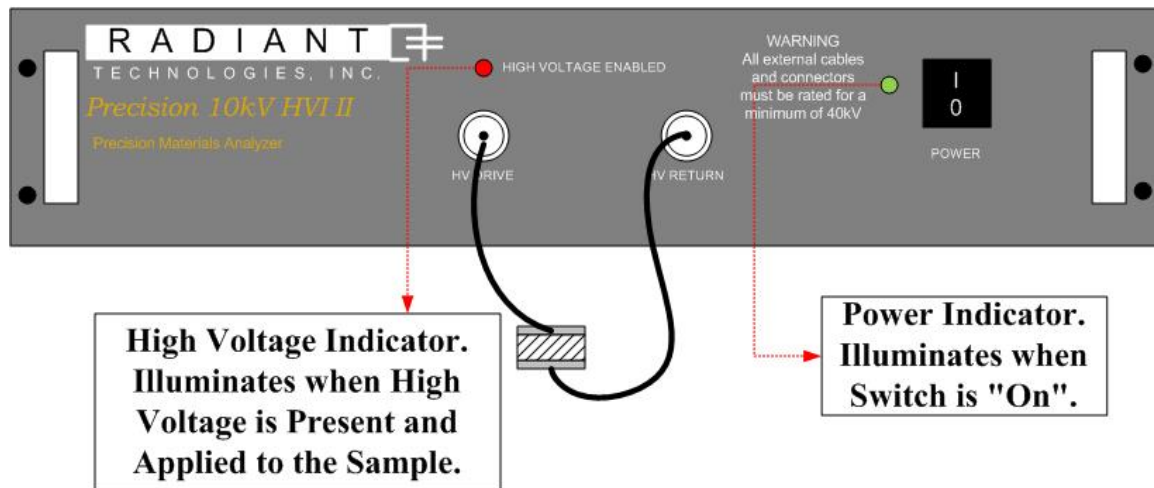

Figure 12 – Precision 10 kV HVI II Front Panel.

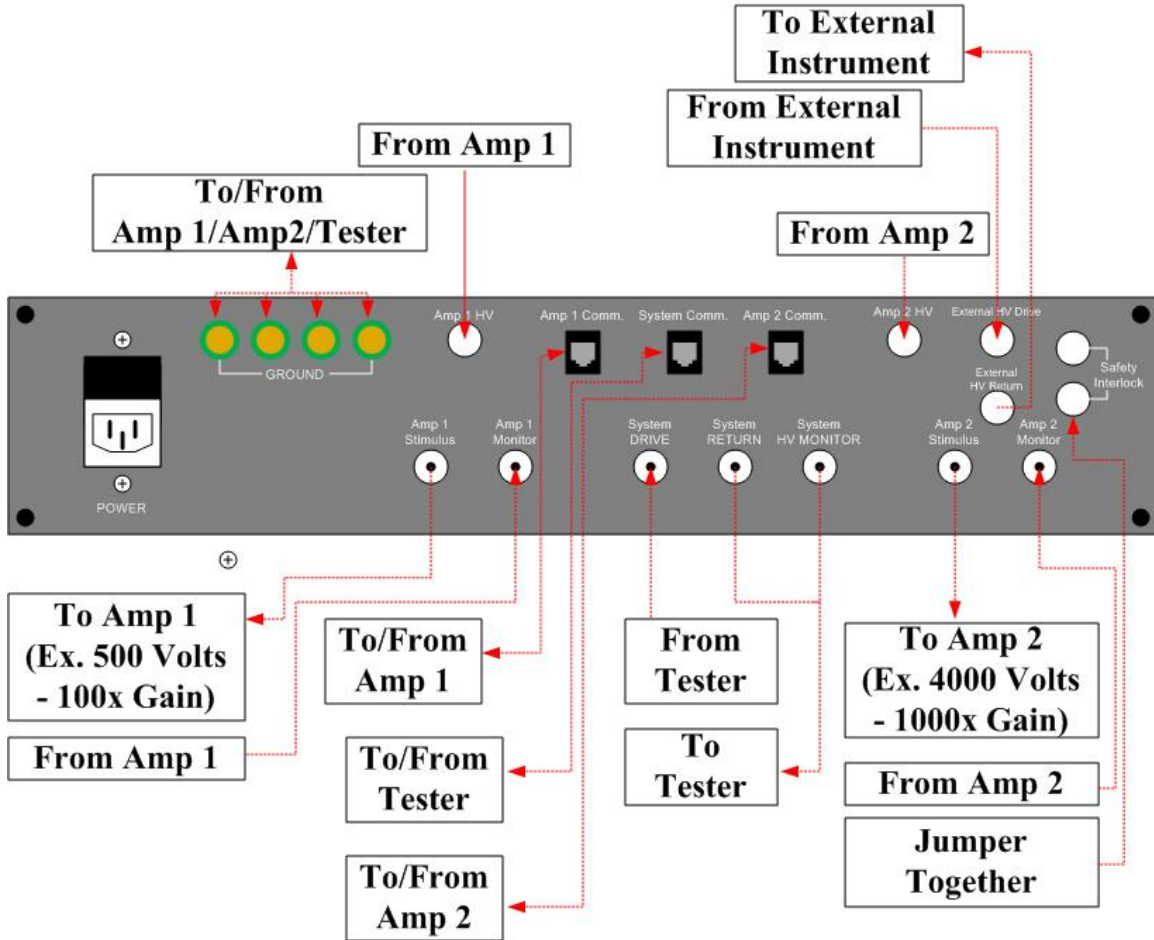

Figure 13 – Precision 10 kV HVI II Rear Panel.

High Voltage Cables

The cables that carry high voltage from the High Voltage Amplifier to the High Voltage Interface and between the HVI and the sample come in two forms.

- 1) The cables with stiff wire with red insulation and plastic connectors on each end are limited to 4kV testing. Lettering on the cable indicates that it is good to 25kV or 30kV DC but Radiant de-rates the voltage limit to 4kV maximum. The reason is that the corners of the triangle wave used to stimulate the sample during hysteresis carry high frequency components that will RF couple out of the cable to grounded metal above the 4kV amplitude. *Only use the cable with the red insulation for tests at 4kV and below.*
- 2) For use above 4kV, Radiant sheaths the 4kV cable in natural rubber tubing that looks like water tubing. With the rubber tubing as extra insulation, the cable is safe to use up to 50kV DC but Radiant de-rates its voltage limit to 10kV to prevent RF coupling from the cable to ground metal.

There are two types of connectors on the high voltage cable. One type of connector is standard on the HVI and HVAs. The other type connects to Radiant's High Voltage Test Fixture. It is a high temperature connector that can withstand up to 230°C. Therefore, high voltage cables for use with the HVTF have two different kinds of connectors on them. The standard high voltage plug for the HVI will not work with the HVTF.

If you desire to go above 230°C, contact Radiant. We supply a test fixture that will go up to almost 1000°C in a tube furnace. It uses alumina sheathed nickel wire for the cabling inside the furnace.

Precision Tester-to-HVI Connections

CONNECT:

TEST SYSTEM	HVI	CONNECTOR TYPE
DRIVE	System DRIVE	BNC
RETURN	System RETURN	BNC
HV MON	System HV MON	BNC
System Comm.	System Comm.	DB25
POWER	POWER	POWER
GROUND	GROUND	BANANA

Table 4 – Tester-to-HVI Connections.

HVI-to-HVA Connections

CONNECT:

HVI	HVA	CONNECTOR TYPE
Amp 1 Stimulus	Stimulus	BNC
Amp 1 Monitor	Monitor	BNC
AMP1 Comm.	Unlabeled	DB25
Amp 1 HIGH VOLTAGE	HV OUT	RED HV CABLE
POWER	POWER	POWER
GROUND	GROUND	BANANA

Table 5 – HVI-to-HVA Connections.

This document has provided a complete description of the connections and indicators on the Precision tester, the High Voltage Interface and a High Voltage Amplifier. This information should be more than sufficient to allow complete system configuration under any experimental conditions. Please refer to the Vision help pages to understand how to configure the software to operate the tester and any accessory equipment. Please contact me immediately if you have any questions or difficulties with system configuration, software configuration and use, sample connections or understanding your data.

Good luck in your research,

Sincerely,

Scott P. Chapman
Computer Engineer